



**Owner's Manual for the
Senior Harvester**



**PREPARED OCT 2018
PART NUMBER 85400**

Senior Harvester Handle Installation

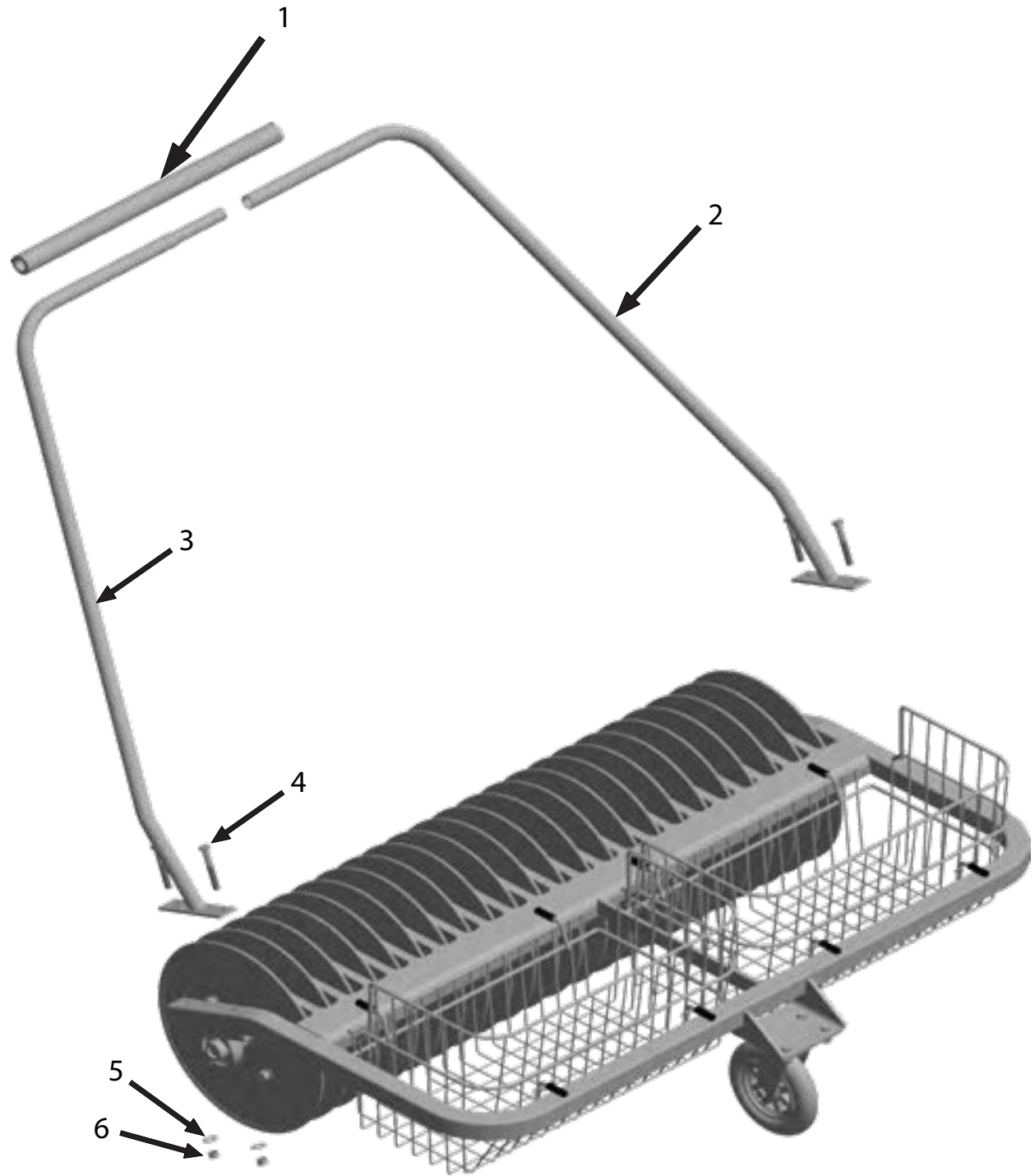

Key Number/Item Description/Quantity/Part Number/Part Number

1	Round Grip	1	85501
2	Left Half Handle	1	85404
3	Right Half Handle	1	85403
4	3/8- 16 x 2.50 Bolt	4	13-01048
5	3/8 Dia. Flat Washer	4	13-01010
6	3/8- 16 Nylon Lock Nut	4	13-01050

Senior Harvester Maintenance



MAINTENANCE PROCEDURES

Lube both (2) Grease Zerks every three months of use. Zerks are found on each Bearing Pillow Block. Bearing Pillow Blocks are located on each side of the Harvester Senior where the Drum Assembly attaches to the Harvester Senior Main Frame.

Senior Harvester Complete Assembly 85400

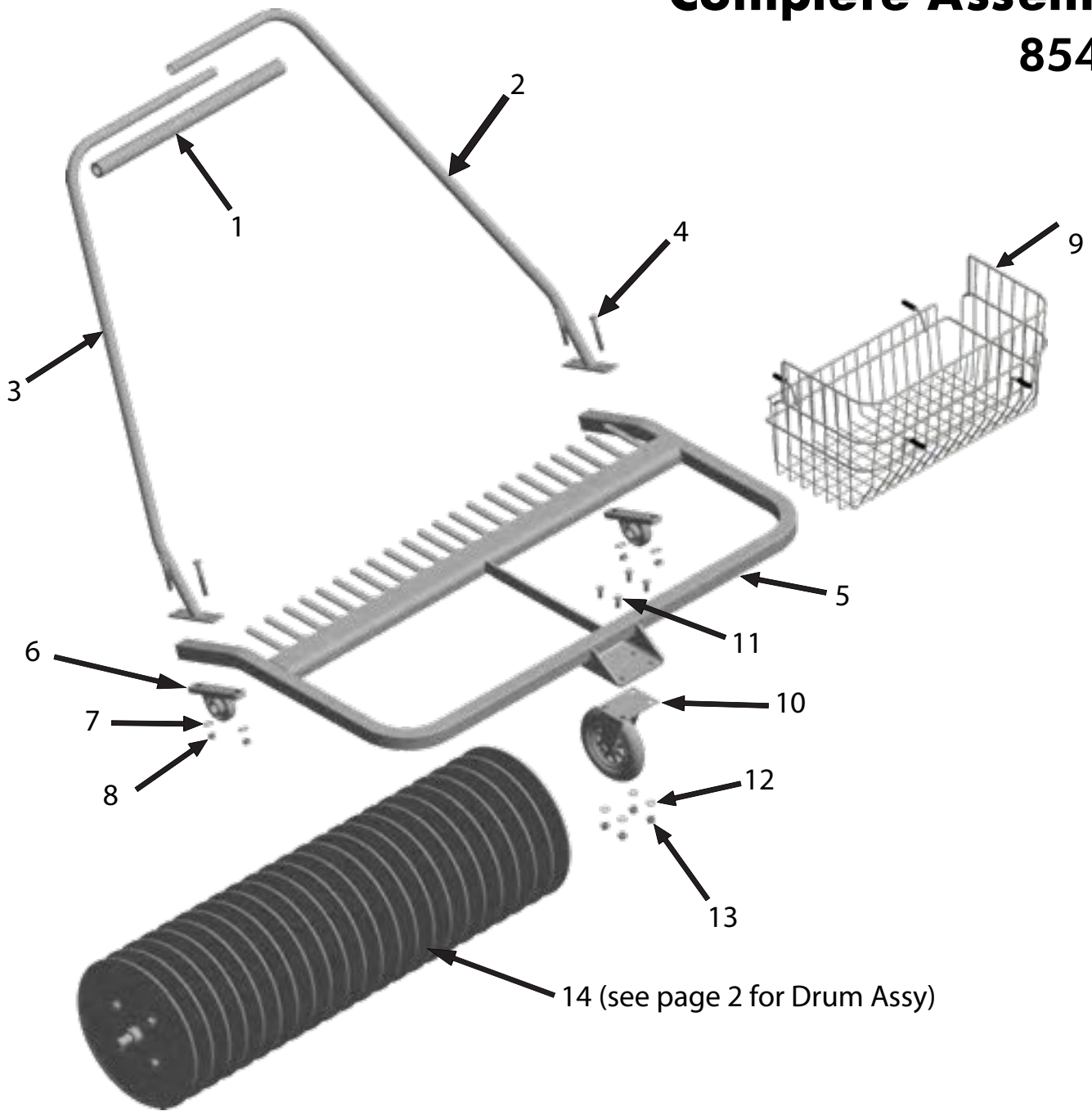

Key Number/Item Description/Quantity/Part Number/Part Number

1	Round Grip	1	85501
2	Left Half Handle	1	85404
3	Right Half Handle	1	85403
4	3/8- 16 x 2.50 Bolt	4	13-01048
5	Main Frame	1	85401
6	Pillow Block	2	83116
7	3/8 Dia. Flat Washer	4	13-01010
8	3/8- 16 Nylon Lock Nut	4	13-01050
9	Wire Basket	2	83119
10	Caster w/ Rubber Wheel	1	85502
11	5/16- 18 x .75 Bolt	4	13-02005
12	5/16 Flatwasher	4	13-02000
13	5/16- 18 Nylon Lock Nut	4	13-01005
14	Drum Assembly	1	85402

Senior Harvester Drum Assembly

85402

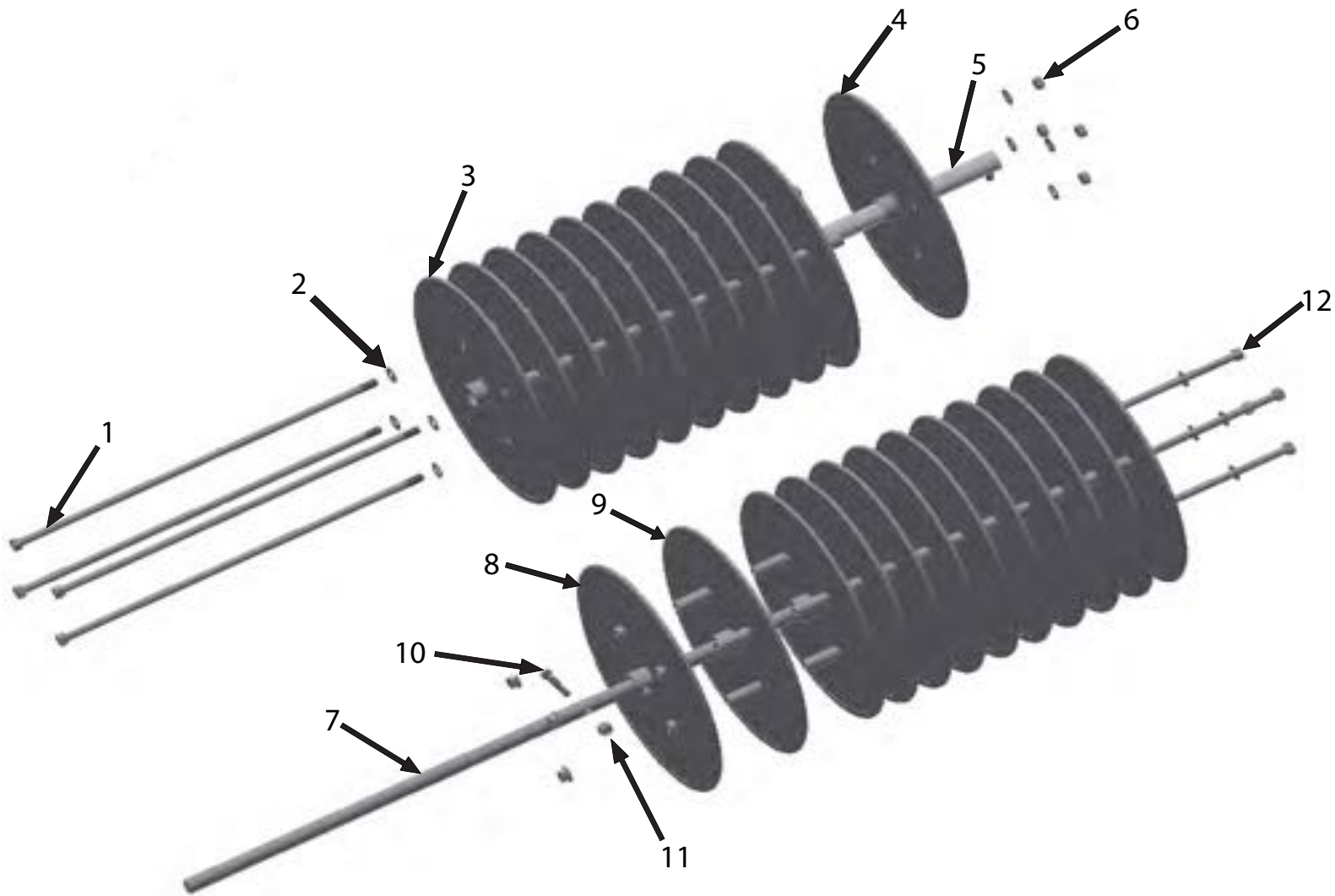

Key Number/Item Description/Quantity/Part Number/Part Number

1	Tie Rod (11) Disc	4	85406
2	3/8 Dia. Flatwasher	16	13-01010
3	Plastic Disc (1.02 Dia. ID)	10	82001
4	Plastic Disc, Pivot Tube	1	85405
5	Pivot Tube	1	85407
6	3/8- 16 Nylon Lock Nut	8	13-01050
7	Axle Shaft	1	85410
8	Plastic Disc, Shaft	1	85205
9	Plastic Disc (.76 Dia ID)	11	81503
10	5/16- 18 x 1.75 Bolt	1	13-01111
11	5/16- 18 Nylon Lock Nut	1	13-01005
12	Tie Rod (12) Disc	4	85409